

EXEC 162F START UP, RUN UP AND TAKE OFF CHECKLIST

1. VERIFY FUEL QUANTITY USING CALIBRATED DIP HOSE.
2. UNTIE BLADES AND PREFLIGHT AIRCRAFT.
3. OIL CHAIN AND CHECK MASTER LINK.
4. CHECK BALLAST WEIGHT LOCATION.
5. POSITION BLADE 45 DEGREES TO THE AIRCRAFT.
6. FASTEN SEAT AND SHOULDER BELTS.
7. CHECK CONTROLS.
8. CLUTCH DISENGAGED.
9. TURN ON FUEL VALVE (DOWN).
10. TURN ON KEY AND INSTRUMENT SWITCH.
11. TURN ON FADEC 1.
12. TURN ON FUEL PUMP 1 AND BOTH IGNITIONS. CHECK FUEL PRESSURE.
13. CONTROLS IN START POSITION.
14. SET THROTTLE TO 0% (IF NECESSARY, ADD THROTTLE TO START).
15. CLEAR AREA AND ENGAGE STARTER.
16. AFTER STARTING, CHECK AND MONITOR OIL PRESSURE AND WATER TEMPERATURE. ADJUST THROTTLE FOR SMOOTH IDLE.
17. ENGAGE CLUTCH.
18. TURN ON FUEL PUMP 2, FADEC 2 AND ALTERNATOR. CHECK FOR VOLTAGE INCREASE.
19. TEST BOTH IGNITIONS, BOTH FUEL PUMPS AND BOTH FADEC SWITCHES. ALL SWITCHES ON WHEN COMPLETE.
20. CHECK FADEC BACKUP SYSTEM, THEN RESET PRIMARY SYSTEM. BOTH SYSTEMS ON.
21. RESET FADEC MAX RPM AND DIAGNOSTIC ERRORS. LEAVE FADEC SET TO DIAGNOSTIC.
22. TURN ON ALTERNATOR AND AVIONICS.
23. IDLE UNTIL WATER AND OIL TEMP IS IN THE GREEN.
24. CHECK FUEL PRESSURE, VOLT METER AND OVER-RUNNING CLUTCH.
25. CHECK CYCLIC POSITION AND INSTRUMENTS IN THE LIGHT POSITION.

EXEC 162F LANDING, COOL DOWN AND SHUT OFF CHECKLIST

1. IDLE AT ZERO THROTTLE UNTIL WATER AND OIL TEMP REDUCE FROM OPERATING TEMP.
2. TURN OFF BOTH FUEL SWITCHES.
3. WHEN ENGINE STOPS, TURN OFF FUEL VALVE.
4. TURN OFF ALL SWITCHES.
5. DISENGAGE CLUTCH.
6. REMAIN INSIDE HELICOPTER UNTIL BLADES STOP.
7. CHECK BEARING TEMPERATURES.
8. POST FLIGHT CHECK.

ROTORWAY INTERNATIONAL**EXEC 162F****PILOT OPERATING HANDBOOK**

This helicopter must be operated in compliance with the operating limitations defined in this handbook.

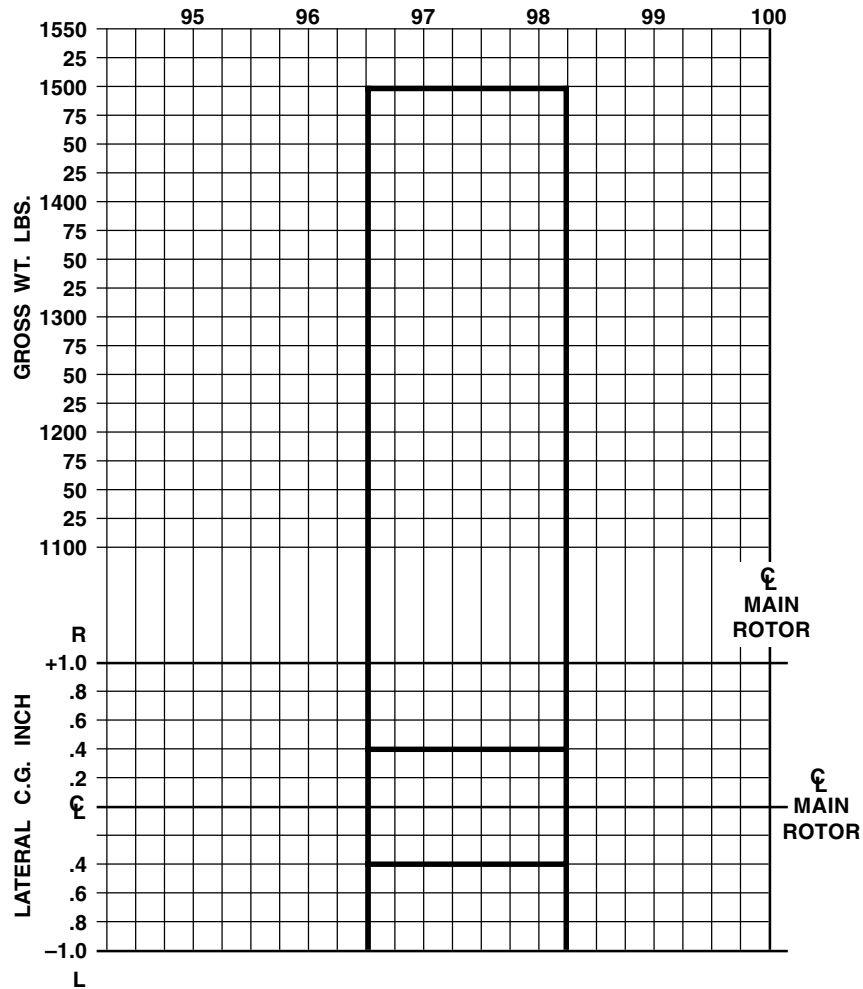
Registration No. _____

Serial No. _____

THIS HANDBOOK SHOULD BE KEPT IN THE ROTORCRAFT AT ALL TIMES.

CONTENTS

**ROTORWAY EXEC 162F
CENTER OF GRAVITY LIMITS
WITH FULL LOTUS FLOATS**



<u>Section</u>	<u>Page</u>
1 RotorWay Exec 162F Specifications	2
2 Limitations	3
3 Normal Procedures	5
4 Emergency Procedures.....	12
5 Performance	16
Height Velocity Envelope	17
Diagram of the Cyclic Control Area of Operation	18
Density Altitude Chart	19
6 Weight and Balance	20
Hang Test Diagram	22
Center of Gravity Calculations	23
Center of Gravity Limits Chart	26
7 FADEC System	27
Instrument Panel Lights Diagram	31
FADEC Digital Display Diagram	32
Overhead Switch Panel Diagram	33
8 Mandatory and Advisory Bulletins	34
9 Full Lotus Floats	35
Center of Gravity Limits With Full Lotus Floats	36
10 HELIPAC Cargo Container	37
RotorWay Exec162F Checklists	38

Section 8. Mandatory and Advisory Bulletins

A Mandatory bulletin contains information that RotorWay International has determined to be important to the safe operation of the helicopter. Mandatory bulletins **MUST** be complied with. An Advisory bulletin contains information about recommended improvements, accessories, or procedures, although compliance is not mandatory.

Modifications referred to in a bulletin are incorporated into production on or before the date the bulletin is issued. Therefore, when an Exec 162F helicopter is shipped, it is in compliance with all bulletins issued up to the shipping date. For example, Bulletin M-09A is a main rotor blade modification; all helicopters shipped after the bulletin date are equipped with modified blades.

Below is a list of all bulletins issued to Exec 162F builders up to the date of this manual. (The Factory sends bulletins to builders free of charge at the date of issue. Additional copies may be purchased from the parts department.)

NUMBER	DATE	DESCRIPTION
M-09	9-28-94	Main Rotor Blades
M-09A	11-28-94	Main Rotor Blades, Modification
M-10	5-12-95	Inertia Switch
M-11	5-12-95	Upper Secondary Bearings
M-12	5-12-95	Ignition Sensors
M-13	7-24-95	FADEC Wiring Harness
M-14	1-2-97	Cam Gear Replacement
M-15	5-5-97	Connecting Rod Inspection
M-16	3-3-98	Throttle Cable Inspection
M-17	4-21-98	Dual Throttle Shaft Weldment
M-18	8-18-99	Fuel Hoses (applies to 162F helicopters delivered 7/95 to 12/96 only)
M-19	1-16-01	Fuel Hoses
M-20	4-4-02	Tail Rotor Belt Installation
M-21	3-14-03	Secondary Shaft Inspection
M-22	7-7-03	Fuel Tank Fitting Rubber Seal
A-20	10-28-94	Tail Rotor Belts, Monitoring
A-21	5-12-95	Tail Rotor Belts, Procedures
A-22	5-12-95	Seat Cushion Modification
A-25	12-21-95	Tail Rotor Belts, Cold Weather
A-26	5-20-96	Secondary Shaft
A-27	5-20-96	Increased Lifetimes of Components
A-28	5-20-96	Elastomeric Bearings
A-29	5-20-96	Prevention of Electrical Interference
A-32	7-1-98	Secondary Drive Unit Installation
A-34	2-23-00	Secondary Shaft (applies to shaft serial numbers 5739 to 5763 only)
A-35	9-21-00	Air Bleed Valve
A-37	4-4-02	Throttle Linkage Adjustment
A-38	5-2-02	Secondary Shaft Upgrade

Section 2. Limitations

Max. airspeed at sea level, standard day 115 MPH (100 knots)

Reduce IAS 2 MPH for each 1000 ft. density altitude

Max. airspeed in turbulent air 75 MPH (65 knots)

Max. sideways, rearwards airspeed 20 MPH (17 knots)

Fuel requirements minimum 92 Octane auto fuel
or 100 low lead AV gas (100LL)

Solo flight from left seat only (right seat belt must be buckled and passenger collective must be removed).

Flight with one or both doors removed is permitted. All items in the cabin must be secured.

Max. gross weight 1500 lbs. (680 kg)

Min. pilot weight (solo operation) 150 lbs. (68 kg)

Max. Cabin Weight 425 lbs. (193 kg)

Max. per seat weight to be determined by PIC (Pilot In Command) using available Weight & Balance formulas and charts located in Section 6 of this manual.

CAUTION

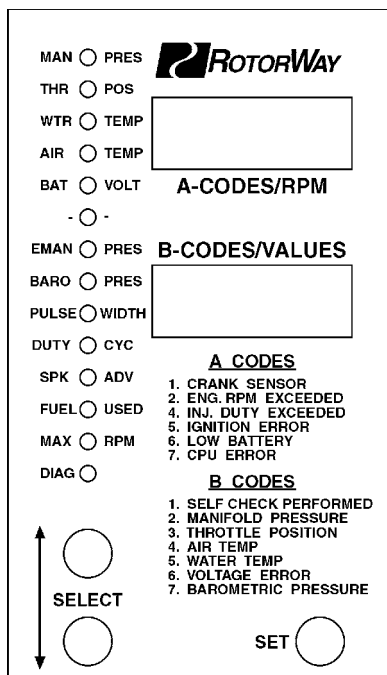
Under no circumstances shall the helicopter be flown if Fore & Aft and/or Lateral CG are not within limits (see chart on page 26).

CAUTION

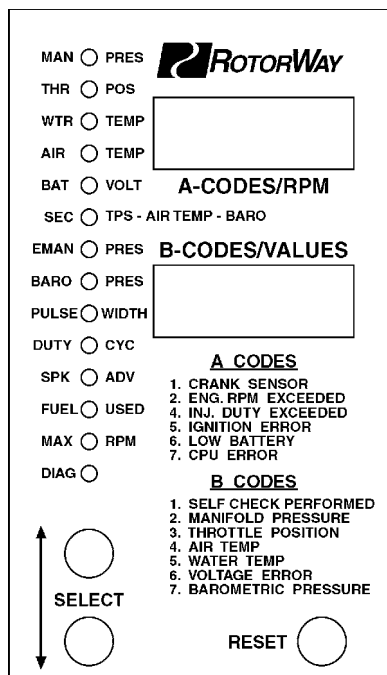
Under no circumstances shall the helicopter be flown if full range of all flight controls is not possible. The cyclic handle position is affected by weight and balance and should remain in the center during normal operations. The cyclic handle should fall within the 6-inch diameter control area of operation in a hover. The outside shaded area is for limited time use only and should be avoided (see diagram on page 18).

FADEC DIGITAL DISPLAY

SINGLE ECU



DUAL ECU



NOTE: The digital display equipped on 162F helicopters with dual ECUs has an additional feature not found on earlier units. To display values of the secondary ECU, choose **SEC** using the **SELECT** buttons. Then press the **RESET** button to toggle between throttle position, air temperature, and barometric pressure values. Pressing the **RESET** button again will cause manifold pressure (2) and water temperature (5) errors in the **B CODES** readout. This is normal, because the secondary system does not have these two sensors. These error codes will remain until a different function is selected.

Section 3. Normal Procedures

Pre-flight checks:

- A. Remove front inspection panel and check:
 1. Security and condition of pedals
 2. Security of front landing gear bracket
 3. Routing and security of all electric wiring
 4. Routing and security of the oil pressure and pitot lines
- B. Remove covers on the right and left seat backs and check:
 1. Torque link for cracks and security
 2. Lower bearing on the main shaft
 3. Condition of main drive belts
 4. Condition of the ignition systems
 5. All airframe tubes for cracks
- C. Engine area right side check:
 1. For oil, fuel, and water leaks, and proper levels
 2. Security and routing of hoses, pipes, and wiring
 3. Heat shielding for cracks and clearance
 4. Security of the rear landing gear brackets

CAUTION: Do not overfill the oil sump. If too much oil is added, the sump must be drained to the proper level. If any oil is spilled, it must be cleaned up before flight.

- D. Tail rotor drive check:
 1. Travel of Idler pulley swing arm (not bottoming out in bulkhead)
 2. Condition and location of drive belts
 3. Tension of drive belts (1-3/8 inch \pm 1/8 inch at 10 lbs. using belt tension tool)
 4. Condition of the pulleys and bearings
 5. Temperature strips on Idler pulleys and drive pulley:
 - 170° F indicates belt slipping or other problem
 - 180° F (or higher) belts have been damaged by heat and must be replaced

IMPORTANT: New belts will tend to stretch and become loose. Belt tension must be monitored and adjusted frequently until stretching has stopped. Check the belt replacement label when adjusting belt tension. Belts must be replaced if more than 1" stretching has occurred since initial tensioning.

NOTE: The belts and pulleys should be kept clean and free of any oil, dirt or other contamination. Use a clean cloth dampened with acetone.

Values

When the display is set to read **VALUES**, the upper readout (A) will continuously indicate engine RPM. The lower readout (B) will show a value for the selected condition. To choose a particular function, press the up or down **SELECT** buttons in the lower left corner of the display unit. The corresponding light will come on to show which function is selected. The functions are as follows:

MAN PRES	Manifold pressure, kPa*
THR POS	Throttle position, %
WTR TEMP	Water temperature, degrees C*
AIR TEMP	Air temperature, degrees C*
BAT VOLT	Battery voltage
EMAN PRES	External manifold pressure (barometric), kPa*
BARO PRES	Barometric pressure, kPa*
PULSE WIDTH	Width of fuel pulse, in milliseconds
DUTY CYC	Duty cycle of fuel injectors, %
SPK ADV	Current spark advance, degrees BTDC This reading will vary with engine RPM and load.
FUEL USED	Fuel used since start up, gallons This refers <u>ONLY</u> to fuel used during the current run cycle of the engine. It will automatically reset every time the ECU is turned off, and can be manually reset by pressing the RESET button. THIS IS FOR REFERENCE ONLY AND MUST NOT BE USED AS AN INDICATION OF FUEL REMAINING IN THE TANKS.
MAX RPM	Maximum RPM achieved during ECU run cycle This can be manually reset by pressing the RESET button.
DIAG	Indicates unit is in diagnostic mode

* Refer to the following conversion tables:

TEMPERATURE

$$\text{Degrees F} = \frac{9 \times \text{Degrees C}}{5} + 32$$

°C	°F	°C	°F	°C	°F
37.8	100	65.6	150	93.3	200
40.6	105	68.3	155	96.1	205
43.3	110	71.1	160	98.9	210
46.1	115	73.9	165	101.7	215
48.9	120	76.7	170	104.4	220
51.7	125	79.4	175	107.2	225
54.4	130	82.2	180	110.0	230
57.2	135	85.0	185	112.8	235
60.0	140	87.8	190	115.6	240
62.8	145	90.6	195	118.3	245

PRESSURE

$$\text{In. Hg} = \text{kPa} \times .296$$

kPa	In.Hg
20.27	6
30.40	9
40.54	12
50.68	15
60.81	18
70.95	21
81.08	24
91.22	27
101.35	30
111.49	33

L. Doghouse check:

1. Security of the master link
2. Tension of the chain
3. Floor of the oil bath for broken rollers and link plates
4. Surge tank level

M. Rotor system check:

1. Security and wear of the scissors
2. For cracks around the ears of the swash plate and the hood bracket
3. For foreign matter in the bearing seal cavity area
4. To see if washer and snap rings on the drive pin are loose
5. End play between shaft and riser blocks
6. For loose bolts
7. Freedom and condition of both control rods

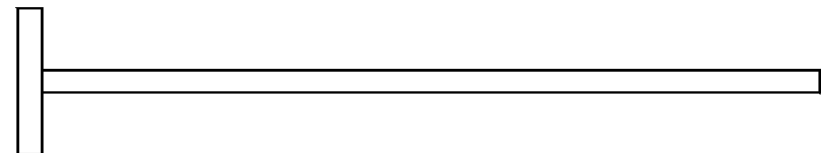
N. Main rotor blades check:

1. All around bolts on retention straps for cracks
2. Bolts for signs of bending
3. Doublers for delamination
4. Blades for wrinkles or cracks near the root end
5. For separation of the skin to spar top and bottom
6. Security of the blade tip end plugs
7. Blade droop for any change

O. Fuel level:

Use a dip hose to check the amount of fuel in the tanks and to verify the accuracy of the fuel gauge.

To calibrate the dip hose, start with the fuel tanks empty and add a measured amount of fuel. Dip the hose all the way into the tank, up to the "T" handle. Take the hose out and permanently mark the fuel level with safety wire. (Insert the wire through the hose, then wrap and tie it securely around the hose.) Repeat the process for additional amounts of fuel. For future reference, record the marks and the corresponding fuel quantity on the dip hose drawing below.



Diagnostic Codes

These codes can only be read when the **DIAG** function is selected. When there is an error in a specific part of the system, the yellow light on the instrument panel comes on and a code number appears in the digital display readout. If multiple errors occur, multiple codes will be displayed in the order in which they occurred.

The numbers that may appear in the upper readout (**A CODES**), are as follows:

1. **CRANK SENSOR** Indicates an error in the ignition sensor (ignition error).
2. **ENGINE RPM EXCEEDED** Indicates that the engine has been operated at speeds higher than 5000 RPM. This error may also result from an intermittent ignition error, or from the signal being interrupted during testing procedures at start-up.
4. **INJ. DUTY EXCEEDED** Indicates that the fuel injectors have operated in excess of their normal duty cycle.
5. **IGNITION ERROR** If there is a malfunction in one of the electronic ignition units, this code will appear.
6. **LOW BATTERY** This code appears when battery voltage drops below 10 volts.
7. **CPU ERROR** This indicates that the system's computer has malfunctioned. If this happens, the FADEC system will automatically switch to the secondary control system. The pilot should make a safe landing as soon as possible until the problem can be resolved.

The numbers that may appear in the lower readout (**B CODES**), are as follows:

1. **SELF CHECK PERFORMED** (ECU error)
2. **MANIFOLD PRESSURE** Indicates an error in the manifold pressure sensor. In the event of a throttle position sensor failure, this sensor is used by the ECU to compute the engine load factor necessary for proper fuel/air ratio.
3. **THROTTLE POSITION** Indicates an error in the primary throttle position sensor. This is the primary sensor used by the ECU.

18. If the yellow light on the instrument panel illuminates during starting or ignition checks, press the RESET button on the digital display monitor. If unable to clear "A" or "B" codes, the aircraft should not be flown until the problem is resolved.
19. Turn on avionics.
20. Idle until water and oil temp is in the green.
21. Check fuel pressure, volt meter and over-running clutch.
22. Check cyclic position and instruments in the light position.

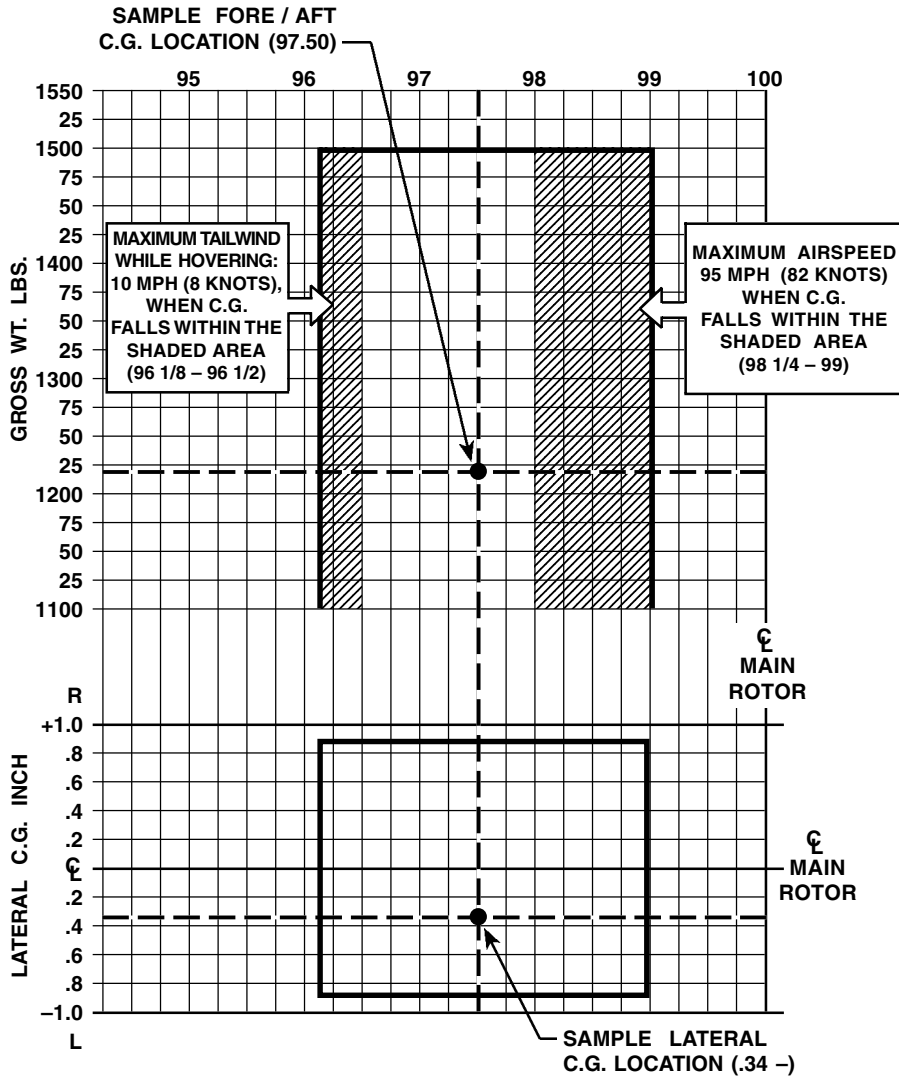
After Started:

Throttle closed while at idle
Cyclic keep centered below 400 RPM

CAUTION: Because of the inline thermostat used in the cooling system, engine RPM **MUST NOT** exceed 2400 RPM until the coolant temperature reaches a minimum of 160° F and the thermostat opens. IF THE ENGINE IS OPERATED AT A HIGHER RPM WHILE THE THERMOSTAT REMAINS CLOSED, EXTREMELY HIGH COOLANT PRESSURES WILL DEVELOP, WHICH MAY RESULT IN DAMAGE TO THE COOLING SYSTEM AND OTHER COMPONENTS.

NOTE: When operating the helicopter in sub-freezing temperatures, it may be necessary to restrict the air flow through the radiator. This will enable the water temperature to stabilize above 160° F during flight. See Engine Manual for further details.

**ROTORWAY EXEC 162F
CENTER OF GRAVITY LIMITS**



**YOUR AIRCRAFT MUST NOT BE OPERATED OUTSIDE OF THE LIMITS
DEFINED ON THIS GRAPH.**

After Landing:

Collective lever lower to 3° pitch
Throttle close to idle when securely on the surface

Shutdown:

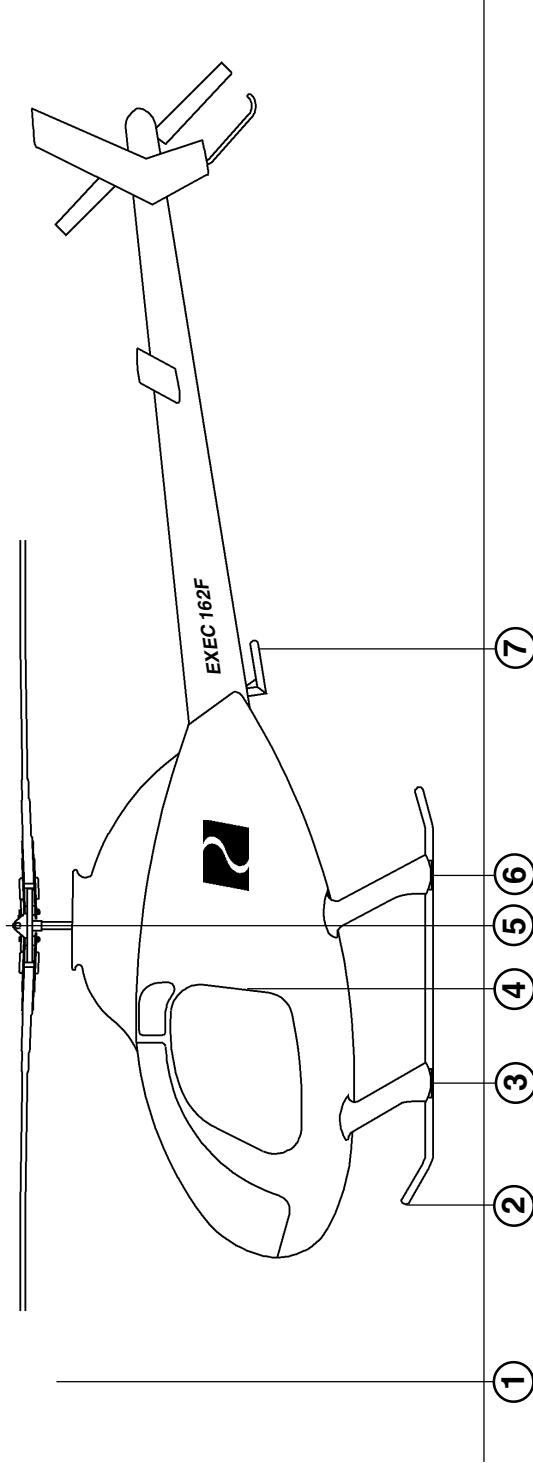
1. Idle at zero throttle until water and oil temp reduce from operating temp. (minimum 10° oil temp. drop).
2. Turn off both fuel switches.
3. When engine stops, turn off fuel valve.
4. Turn off all switches.
5. Disengage clutch.
6. Remain inside helicopter until blades stop.
7. Post flight checks.

Post flight checks:

Master link on chain in position
Swash plate bearing check temperature
Main thrust bearing check temperature
Upper secondary bearing check temperature (170° to 190° F)
Tail boom check for wrinkles and temperature of bulkheads
Tail rotor belt tension at inspection hole in tail boom
between "loose" and "tight" limit marks on tension tool
Tail rotor pulleys check temperature (under 180° F)
Tail rotor inspect
Vertical stabilizer secure
Main rotor blades tie to tail boom

FORE/AFT ARM INCH	
1. DATUM	0
2. FORWARD WEIGHT POSITION	37.25
3. FORWARD WEIGHING POINT	55.75
4. SEATS	71.0
5. MAIN SHAFT AND GAS TANKS	100.0
6. REAR WEIGHING POINT	109.25
7. REAR WEIGHT POSITION	163.0

LATERAL ARM INCH	
PASSENGER SKID	+31.5R
PASSENGER SEAT	+10.5R
PASSENGER GAS TANK	+18.5R
PILOT SKID	-31.25L
PILOT SEAT	-10.25L
PILOT GAS TANK	-18.25L

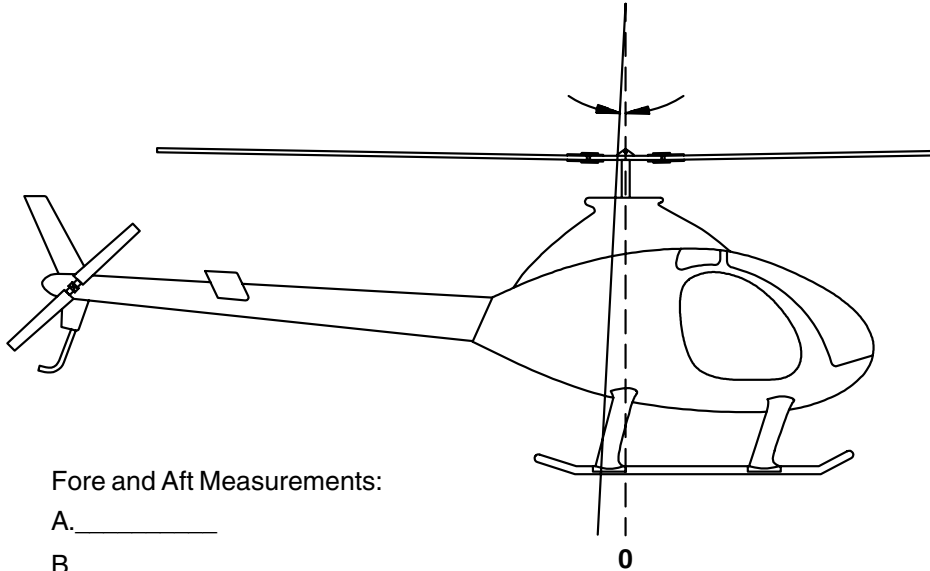


DATUM SCALE IS GRADUATED IN INCHES. THESE CALCULATIONS ARE DETERMINED WITH THE MAIN ROTOR SHAFT 90 DEGREES TO THE GROUND WHEN THE AIRCRAFT IS WEIGHED.

- D. Engine failure above 500 feet AGL:
 1. Lower collective to maintain rotor RPM and enter normal autorotation (see page 16).
 2. Establish a steady autorotation descent at approximately 65 MPH.
 3. Adjust collective to keep rotor RPM 100%.
 4. After a steady autorotation is established, select a landing spot and maneuver as required so the landing will be upwind.
 5. A restart may be attempted at pilot's discretion, if sufficient time is available.
 6. If unable to restart, turn off unnecessary switches and shut off the fuel valve if sufficient time is available.
 7. At about 35 feet AGL, begin a cyclic flare to reduce forward and descent speed. Level at 3 to 5 feet of clearance between the tail rotor and the ground. Increase collective pitch to cushion ground contact as the aircraft settles below 30 inches AGL.
 8. Maintain heading with the pedals.

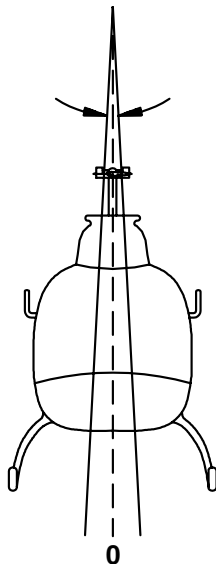
- E. Glide distance configuration:
 1. Airspeed approximately 65 MPH.
 2. Rotor RPM approximately 100%
 3. Increase rotor RPM to 104% when below 500 feet AGL.

HANG TEST DIAGRAM



Fore and Aft Measurements:

- A. _____
 B. _____
 C. _____



Lateral Measurements:

- A. _____
 B. _____
 C. _____

- J. Tail rotor failure during hover:
1. Failure is usually indicated by a left yaw which can not be corrected by applying right pedal.
 2. Immediately close the throttle and perform a hovering power off landing.
 3. Keep the ship level with the cyclic and increase the collective just before touchdown to cushion landing.
- K. Tail rotor failure during forward flight:
1. Failure is usually indicated by a right or left yaw which can not be corrected by applying pedal.
 2. Immediately enter a shallow descent into the wind.
 3. **CAUTION: If sideslip is excessive and the aircraft tends to spiral, immediately enter an autorotation and plan a power off landing, (full touchdown auto) with throttle off.**
 4. Adjust the collective and the throttle to extend the glide **ONLY** if sideslip is not excessive and the aircraft does not tend to spiral. Select a landing site and perform a run-on landing, touching down at a speed well above translational lift, using throttle to maintain heading. **CAUTION: Attempting a run-on landing with a tail rotor failure requires extreme pilot skill.**
- L. Engine fire during starting on the ground:
1. Turn off fuel pumps.
 2. Turn off fuel valve.
 3. Turn off all other switches if time permits.
 4. Extinguish the fire with a fire extinguisher or whatever is available.
 5. Inspect for damage.

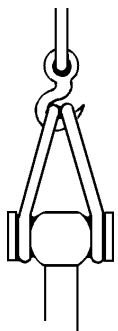
Section 6. Weight and Balance

The center of gravity (C.G.) requirement for any helicopter is very important to its safe operation. In order to determine that your RotorWay EXEC 162F has been built correctly and the weight and balance is correct, you will have to perform a static hang test.

Prior to performing the hang test, the following operating conditions and limitations should be reviewed:

1. The empty weight of the EXEC 162F is 975 lbs. (442 kg)
2. The maximum take off weight is 1500 lbs. (680 kg)
3. The maximum variable load, consisting of pilot, passenger, fuel, and any ballast is 525 lbs. (238 kg)
4. Maximum cabin weight is 425 lbs. (193 kg)
5. SOLO flight is performed ONLY FROM THE LEFT SEAT and must have the ballast weight placed on the front passenger skid. The cyclic handle should fall within the 6 inch diameter control area of operation in a hover (see diagram on page 18).
6. DUAL flight requires the ballast weight be placed on the rear mount tube under the tail boom. Again the cyclic handle should fall within the 6 inch diameter control area of operation in a hover (see diagram on page 18).

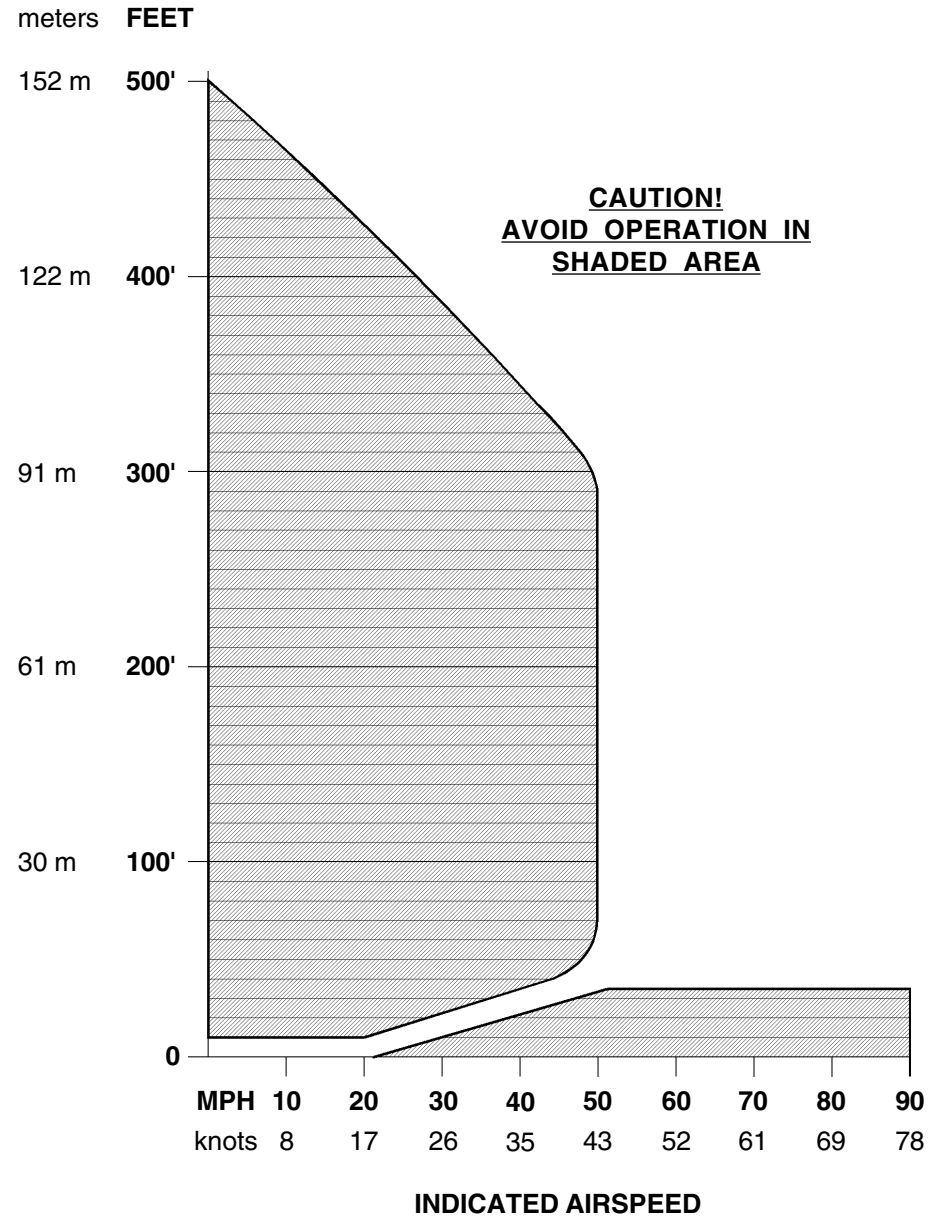
The hang test requires a facility that will allow the aircraft to be suspended approximately 6 inches from the ground, hanging from the knuckle of the main rotor shaft (see sketch below).



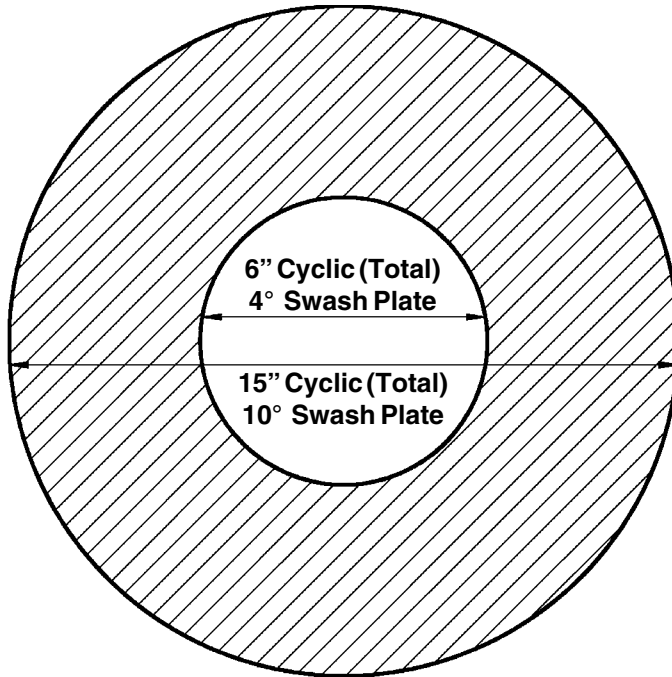
NOTE: Hook should be centered over shaft to distribute weight evenly.

HEIGHT VELOCITY ENVELOPE

NOTE: Out of ground effect (O.G.E.) hovers are prohibited for all Exec pilots under 150 hours.

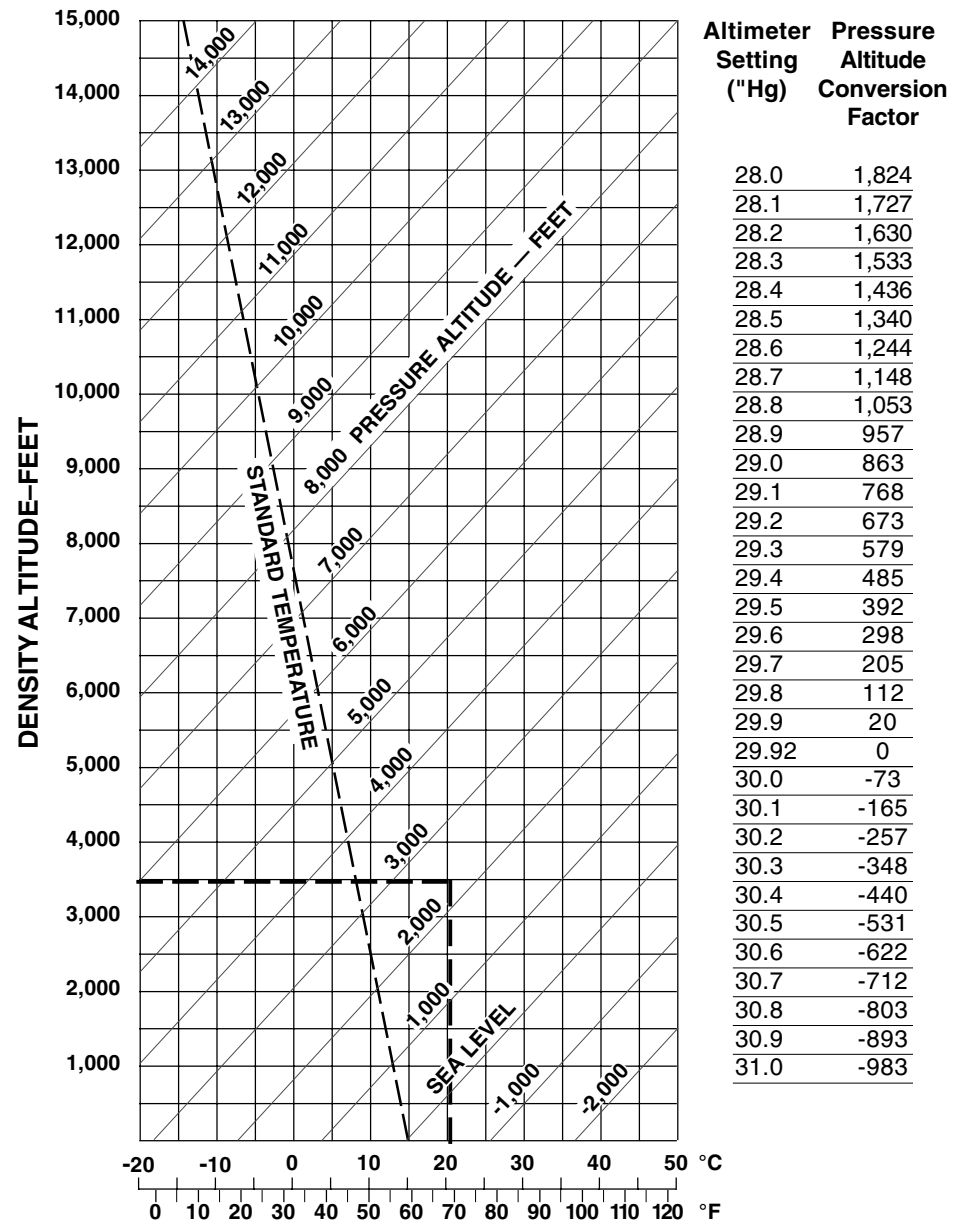


**DIAGRAM OF THE CYCLIC CONTROL
AREA OF OPERATION**



1. Cyclic handle position is affected by weight and balance.
2. The helicopter must be rigged in compliance with the rigging instructions provided.
3. The cyclic handle should remain in the center during normal operations.
4. The shaded circle is for limited time use only.

DENSITY ALTITUDE CHART



Example: Pressure altitude 2,200 (altimeter set at 29.92)
Temperature 70° F = Density Altitude 3,500 ft.

Section 5. Performance

Hover in ground effect	7000 feet (2133 m)
Hover out of ground effect	5000 feet (1524 m)
Service ceiling	10,000 feet (3048 m)
Range with maximum fuel at optimum cruise power	180 miles/2hrs. (289 kilometers)
Normal cruise	95 MPH (82 knots)
Maximum airspeed	115 MPH (100 knots)

Autorotation Procedure From Altitude:

For asymmetrical rotor blades

1. Lower collective **FULL DOWN**, apply left pedal to maintain trim, adjust cyclic to maintain level attitude.
2. Adjust collective to maintain rotor RPM within the green (100%).
3. Adjust airspeed to 65 MPH (60-70 MPH limit).
4. Begin cyclic flare at approximately 35 feet AGL using approximately 30 degree flare angle. Level aircraft at 3–5 feet of clearance between the tail rotor and the ground. Rotor RPM should typically increase 5–7% during the flare.
5. During level off, add collective pitch if you are settling too rapidly.
6. Allow aircraft to settle to 30 inches AGL. As the aircraft settles below 30 inches, apply collective pitch to cushion ground contact.

NOTE: AUTOROTATION TO THE GROUND IS NOT RECOMMENDED DURING TRAINING AND PRACTICE.

For this test to be accurate the aircraft must be complete with the following:

1. Full coolant and oil in aircraft
2. No fuel in tanks
3. Enclosed area, no wind

There will be three test configurations of the aircraft, each with a different cabin loading. If the helicopter falls within plus or minus 1/2 degree both laterally and fore/aft of the specified angles of the three tests, and if the helicopter has been properly rigged, the aircraft should be ready for the first run-ups and liftoffs.

NOTE: During all tests the main rotor blades must remain in the fore and aft position (parallel to the tail boom). Values do not include doors or avionics package.

Using the Hang Test Diagram on page 22, the following results should be obtained within 1/2 degree (plus or minus) in all three tests:

- A. EMPTY AIRCRAFT (no cabin weight, ballast weight in solo front skid location):
Fore and Aft 3° aft
Lateral 2° passenger side
- B. PILOT ONLY 150 lbs. (ballast weight in solo front skid location):
Fore and Aft 1° fore
Lateral 0°
- C. PILOT 210 lbs. and PASSENGER 210 lbs. (ballast weight in rear dual location):
Fore and Aft 5° fore
Lateral 1/2° passenger side

The results of these tests should be recorded in the appropriate columns on the diagram provided on page 22.

IMPORTANT: If you are unable to achieve the results specified above within plus or minus 1/2 degree, contact RotorWay Customer Service Department for assistance before attempting to lift off the aircraft. The weight and balance of any helicopter is critical and this helicopter should not be flown until the pilot is aware of the weight and balance schedule and the hang test has been satisfactorily performed.

- F. Engine fire in flight:
 1. Enter autorotation.
 2. Shut off fuel pumps then fuel valve if time is available.
 3. Execute an autorotation landing. After landing, if time permits, turn off ignition, instrument and alternator switches.
 4. Extinguish fire and inspect for damage.
- G. Electrical fire in flight:
 1. FADEC, instrument, ignition, and fuel pump switches on.
 2. All other switches off.
 3. Land immediately.
 4. Extinguish fire and inspect for damage.

(NOTE: Do not switch ignition off unless the engine has stopped).

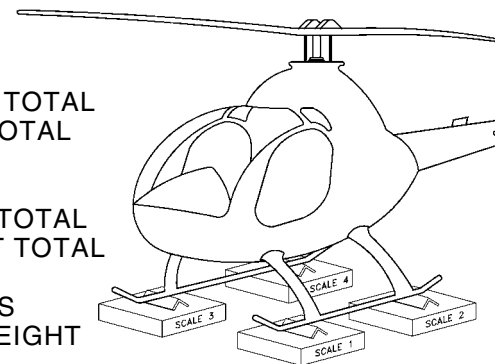
- H. Air restart procedure:
Set throttle to zero. Press starter button on the cyclic.

CAUTION: IF AN ENGINE MALFUNCTION OCCURS, DO NOT ATTEMPT A RESTART UNTIL A SAFE AUTOROTATION IS ESTABLISHED.

- I. Tachometer failure:
If the rotor or engine tach malfunctions in flight, use the operational tach to make a normal landing.

Center of Gravity

In addition to the hang test, it will be necessary to find the aircraft's center of gravity. Place the aircraft on scales at the forward and rear weighing points as shown in the illustration below. (Exact placement is shown in the diagram on page 24.) Then, using the example on page 25, calculate the center of gravity of your helicopter.



FORE/AFT
SCALE 1 + SCALE 3 = FORE TOTAL
SCALE 2 + SCALE 4 = AFT TOTAL

LATERAL
SCALE 1 + SCALE 2 = LEFT TOTAL
SCALE 3 + SCALE 4 = RIGHT TOTAL

SCALE 1 + 2 + 3 + 4 EQUALS
TOTAL AIRCRAFT EMPTY WEIGHT

WEIGHT AND BALANCE CALCULATIONS (EMPTY WEIGHT)

No ballast weight, no fuel in aircraft.

Weight x Arm Inch = Moment Inch

Total Moment Inch ÷ Total Weight = Balance Location

	<u>WT. LBS</u>	<u>ARM INCH</u>	<u>MOMENT INCH LBS.</u>
FORE/AFT			
Front Scales (Fore Total)	_____	x _____	= _____
Rear Scales (Aft Total)	_____	x _____	= _____
TOTAL WT.	_____	TOTAL MOMENT	_____
LATERAL			
Pilot Skid (Left Total)	_____	x _____	= _____
Pass. Skid (Right Total)	_____	x _____	= _____
TOTAL WT.	_____	TOTAL MOMENT	_____

TOTAL WEIGHT: _____ FORE/AFT CG: _____ LATERAL CG: _____

NOTE: THE MAIN ROTOR SHAFT MUST BE 90° TO THE GROUND WHEN THE AIRCRAFT IS WEIGHED. MAKE SURE TO SUBTRACT THE WEIGHT OF ANYTHING ON THE SCALES THAT IS NOT PART OF THE HELICOPTER (ANGLE BARS, WOOD BLOCKS, ETC.) SOME ERROR CAN OCCUR ON THE FORWARD SCALE VALUES IF THE SKIDS DO NOT SET SQUARE TO THE GROUND OR SCALES.

Section 4. Emergency Procedures

- A. Engine failure General:
1. A change in noise level, a right yaw and low oil pressure may be the first indication of an engine failure.
 2. Engine failure at high speed, high power, will result in a tendency for the helicopter to pitch nose up.
- B. Engine failure below approximately 8 feet AGL:
1. Maintain level attitude with cyclic.
 2. Apply left pedal as required to prevent yawing.
 3. Collective pitch should not be reduced by any significant extent.
 4. Increase collective just before touchdown to cushion landing.
- C. Engine failure between 8 feet and 500 feet AGL:
1. Lower collective lever to maintain rotor RPM. The amount of and duration of collective reduction depends upon the height above the ground at which the engine failure occurs.
 2. If height permits, adjust collective to achieve 100% rotor RPM.
 3. Use cyclic and collective as required to carry out engine off landing.
 4. Maintain heading with pedals.

SAMPLE WEIGHT AND BALANCE AIRCRAFT ON SCALES

No ballast weight, no fuel in aircraft.

Weight x Arm Inch = Moment Inch

Total Moment Inch ÷ Total Weight = Balance Location

FORE/AFT	WT. LBS		ARM INCH	=	MOMENT INCH LBS.
Front Scale	71	x	55.75	=	3958.25
Rear Scale	<u>853</u>	x	109.25	=	<u>93190.25</u>
	924				97148.50

97148.50 ÷ 924 = **105.13 FORE/AFT CG LOCATION**

LATERAL	WT. LBS		ARM INCH	=	MOMENT INCH LBS.
Passenger Skid	474	x	31.5+	=	14931.0
Pilot Skid	<u>450</u>	x	31.25 -	=	<u>14062.5 -</u>
	924				868.5

868.5 ÷ 924 = **.94+ LATERAL CG LOCATION**

SAMPLE WEIGHT AND BALANCE SOLO FLIGHT

FORE/AFT	WT. LBS		ARM INCH	=	MOMENT INCH LBS.
Basic Weight	924	x	105.13	=	97140.12
Ballast Wt. Forward	27	x	37.25	=	1005.75
Pilot	210	x	71.00	=	14910.00
Fuel	<u>60</u>	x	100.00	=	<u>6000.00</u>
	1221				119055.87

119055.87 ÷ 1221 = **97.50 FORE/AFT CG LOCATION**

(See chart on page 26)

LATERAL	WT. LBS		ARM INCH	=	MOMENT INCH LBS.
Basic Weight	924	x	.94+	=	868.5+
Ballast Wt. Pass. Skid	27	x	31.50+	=	850.5+
Pilot	210	x	10.25 -	=	2152.5 -
Fuel Pilot	30	x	18.25 -	=	547.5 -
Fuel Pass.	<u>30</u>	x	18.50+	=	<u>555.0+</u>
	1221				426.0 -

426 - ÷ 1221 = **.34 - LATERAL CG LOCATION**

(See chart on page 26)

Run up:

Oil temperature green
 Oil pressure green
 Water temperature green
 Clutch handle in
 Pedals centered
 Cyclic centered
 Collective lever set 3° to 3-1/2° positive
 Throttle slowly increase to 100% rotor RPM
 Battery voltage check for charge

NOTE: During run up and run down, engine operation between 2500 and 3000 RPM should be limited due to main drive belt resonance frequency.

Take off:

Pedals even to half right pedal
 Cyclic within 3 inches of center

The pilot should determine the correct control position during take off by noting and responding to the small movements of the aircraft when it becomes light on the skids.

Slowly raise collective, adjusting throttle to maintain rotor RPM in the green.

Economical cruise manifold pressure 4 inches less than hover
 Rotor RPM (in green) 96 – 104% maintain in flight

Take off and operation should be conducted per height velocity envelope diagram (see page 17).

During flight, check all instruments for anomalies.

NOTE: If the yellow light on the instrument panel illuminates during flight, the helicopter should be safely landed. The pilot can identify the problem and respond accordingly. If the red light illuminates during any operation of the aircraft, the aircraft should be landed immediately and the problem determined and resolved before resuming flight.

CAUTION: DO NOT RESET THE DIGITAL DISPLAY MONITOR IN CASE OF “A” OR “B” FAULT CODES WHILE IN FLIGHT. DO NOT RESET THE PRIMARY SYSTEM IN FLIGHT IF THE SECONDARY SYSTEM IS IN OPERATION.

Section 7. FADEC System

RotorWay International’s FADEC (Fully Automated Digital Electronic Control) is an electronic engine control system that is unique in the aviation industry. The system is fully redundant; if failure of the primary system occurs, a backup system will automatically activate.

One of the outstanding features of this system is the digital display monitor. By using the **SELECT** buttons, the pilot can view a number of different engine conditions. A light will illuminate next to the chosen function, and a value for that function will appear in the readout. This information is gathered by sensors located throughout the system.

When the **DIAG** function is selected, the display will show the relevant codes. Normally, a zero will appear in each readout. However, if a problem arises, a diagnostic code number will appear. The pilot can identify the problem and respond accordingly.

NOTE: To reset diagnostic errors, max RPM and fuel used values, etc., first choose the desired function using the **SELECT** buttons, then press the **RESET** button.

Before starting:

1. Verify fuel quantity using calibrated dip hose.
2. Untie blades and preflight aircraft.
3. Oil chain and check master link.
4. Check ballast weight location.
5. Position blade perpendicular to the aircraft.

WARNING: When the starter is engaged, all drive train components will turn, including the main rotor blades.

Starting (See Overhead Switch Panel Diagram on page 33):

1. Set Altimeter
2. Fasten and adjust seat and shoulder belts.
3. Secure doors.
4. Check cyclic, collective, and pedals for full travel and freedom of travel.
5. Clutch disengaged.
6. Turn on fuel valve.
7. Turn on key and instrument switch.
8. Turn on FADEC 1 switch. The green FADEC 1 light on the instrument panel should come on.
9. Turn on fuel pump #1 and both ignition switches and check fuel pressure (50–60 PSI).
10. Controls in start position.
11. Set throttle to 0% (if necessary, add throttle to start engine).
12. Clear area and engage starter.
13. After starting, check and monitor oil pressure (40-80 psi within 5 seconds) and water temperature (slowly rising). Adjust throttle for smooth idle (if necessary).
14. Engage clutch.
15. Turn on fuel pump #2, FADEC 2 and alternator. Check for voltage increase.
16. Test both ignitions, both fuel pumps, and both FADEC switches. All switches on when complete.
17. With the engine running, check FADEC system as follows: Turn off FADEC 1 switch. The green FADEC 1 light should go off and the red FADEC 1 light should come on. The engine should be running on the secondary system, and the digital display should be blank. Reset the primary system by switching FADEC 1 on and switching FADEC 2 off then on again. The green FADEC 1 and 2 lights on the instrument panel should come on, and the red lights should be off.

(continued)

4. **AIR TEMP** Indicates an error in the air temperature sensor.
5. **WATER TEMP** Indicates an error in the water temperature sensor. This sensor is used for cold starting, and has no effect at temperatures above 50° C.
6. **VOLTAGE ERROR** indicates a problem in the alternator or voltage regulator.
7. **BAROMETRIC PRESSURE** Indicates an error in the barometric pressure sensor. This sensor is used for altitude fuel mixture compensation. Loss of this sensor will cause the engine to run in a rich condition above 4000 feet and run in a lean condition below 3000 feet (default 3500 MSL).

NOTE: During start up and ignition checks, the following **A CODES** may appear: **1, 2, 5, 6**. Normally these are momentary conditions, for example, **6** (low battery) may appear during cranking. While in **DIAG** mode, pressing the **RESET** button will clear these error codes and turn off the yellow light on the instrument panel.

If any **B CODES** appear during start up, do not fly the aircraft until the problem is located and resolved. Pressing the **RESET** button will clear the code if the problem was momentary, but the cause of the problem should still be found. Refer to the Engine Manual for further details.

CAUTION: If any of the following codes appear during flight, the helicopter should be landed safely and flight discontinued until the problem is located and resolved:

A CODES: 1, 2, 5, 6

B CODES: 2, 3

These codes correspond to the **PRIMARY** sensors used by the main ECU. Although this system is fully redundant, loss of these sensors will result in relying only on the backup system for safety.

NOTE: Because the tail rotor belts become tighter as the temperature increases, observe the following procedures during cold weather:

1. Check and adjust the belts in an environment that is approximately the same temperature that the helicopter will be operated in.
 2. Adjust the belts to the loose end of the range so that as they warm up, they will be within limits.
 3. Allow the aircraft to run long enough for the coolant and oil temperatures to stabilize, then shut down and immediately check the belt tension again.
- E. Tail rotor check:
1. Freedom of travel
 2. Slider on key
 3. Freedom and condition of the rod ends
 4. For cracks in the skins around the 3/16 retention bolts and pop rivets
 5. End play on the blades and security of the snap rings and pivot bolts
- F. Vertical trim fin check:
1. Structural security and angle
- G. Horizontal trim fin check:
1. Structural security and angle
 2. Security of winglets
- H. Tail boom check:
1. For cracks, wrinkles, and structural security
- I. Engine area left side check:
1. Oil, fuel, and water leaks
 2. Security and routing of hoses, pipes, lines, and wiring
 3. Condition and tension of the fan drive and main drive belts
 4. Clutch and idler pulley
 5. Security of the rear landing gear brackets
 6. For cracks and security of heat shielding
- J. Collective control check:
1. Freedom of travel
 2. All linkages for security
 3. Throttle roll and butterfly travel
- K. Cyclic control check:
1. Freedom of travel
 2. Bias of the cables and security of rod ends

Instrument Panel Lights - Single ECU

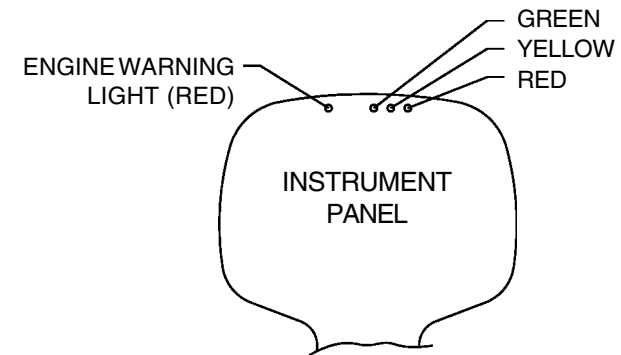
On 162F helicopters equipped with a single ECU, four lights are mounted at the top of the instrument panel. These indicate the following:

Engine warning light (Red): Engine has stopped or dropped below 1800 RPM

Green: FADEC System is activated and operating on primary ECU

Yellow: An error has occurred (check the diagnostic code that appears in the readout)

Red: The primary ECU is disabled, engine is running on secondary system



Instrument Panel Lights - Dual ECU

On 162F helicopters equipped with dual ECUs, six lights are mounted at the top of the instrument panel. These indicate the following:

Engine warning light (Red): Engine has stopped or dropped below 1800 RPM

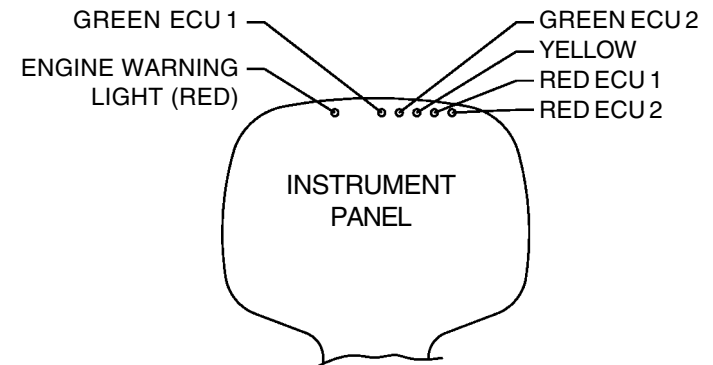
Green ECU 1: FADEC System is activated and operating on primary ECU

Green ECU 2: Secondary ECU is on standby if primary ECU is active; or secondary ECU is operating if primary ECU is off.

Yellow: An error has occurred (check the diagnostic code that appears in the readout)

Red ECU 1: The primary ECU is off

Red ECU 2: The secondary ECU is off



Instrument Markings

Color code for instrument markings:

- GREEN: Normal operating range
- YELLOW: Cautionary operating range
- RED: Indicates maximum operating limits. The pointer should not enter the red during normal operation.

Voltage:

Green arc 12-1/2 to 14-1/2

Oil pressure:

Green arc 40 – 80 PSI

Red line below 40 and above 80 PSI

Oil temperature:

Low yellow arc 100° – 140°F

Green arc 140° – 230°F

High yellow arc 230° – 250°F

Red line 250°F

Water temperature:

Low yellow arc 100° – 140°F

Green arc 140° – 190°F

High yellow arc 190° – 215°F

Red line 215°F

Rotor RPM:

Low red line 90%

Low yellow arc 90% – 96%

Green arc (100% = 520 RPM) 96% – 104%

High yellow arc 104% – 110%

High red line 110%

Engine RPM:

Green arc 96% – 104%

High red line 110%

Airspeed:

Red line 115 MPH (100 knots)

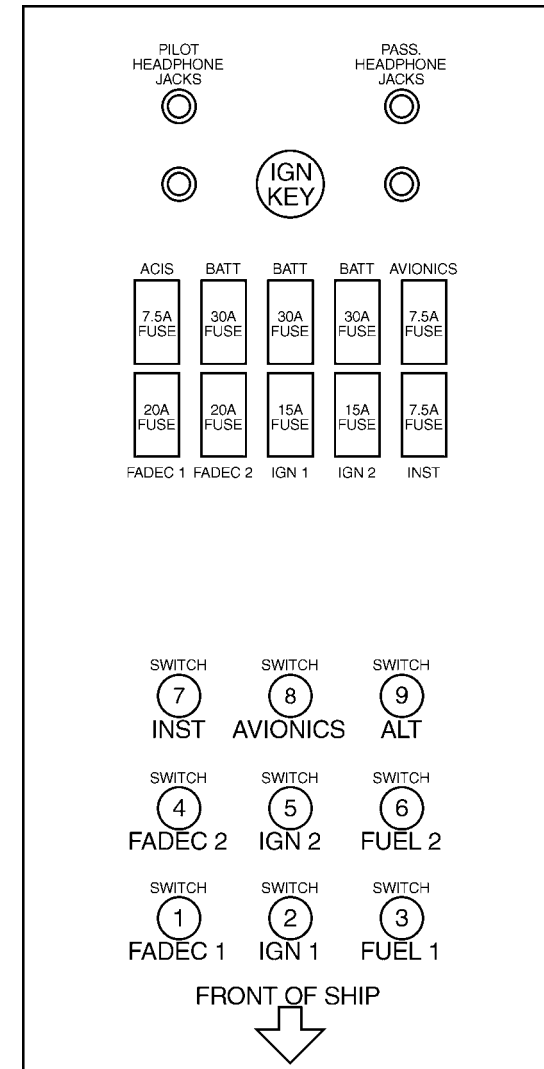
Manifold Pressure:

Red Line (with ACIS supercharger) 34 in. Hg

NOTE: On Exec 162F helicopters equipped with the ACIS supercharger, manifold pressure is controlled electronically by the ECUs and stepper motor controller. However, it is ultimately the pilot's responsibility to monitor and maintain manifold pressure within acceptable limits.

On Exec 162F helicopters with normally aspirated engines, there is no red line limit for manifold pressure.

OVERHEAD SWITCH PANEL DIAGRAM (AS VIEWED FROM BELOW)



Section 1. RotorWay Exec 162F Specifications

Powerplant	RI 162F liquid cooled, four stroke, 162 cubic inches (2659 cc)
Seats	2
Gross weight	1500 lbs. (680 kg)
Empty weight	975 lbs. (442 kg)
Equipped useful load	525 lbs. (238 kg)
Fuel capacity	17 U. S. Gallons (64 liters)

Section 9. Full Lotus Floats

- A. The aircraft airspeed red line (Vne) at standard conditions is reduced to 80 MPH (69 knots) when flying the aircraft configured with floats.
- B. The fore/aft center of gravity limits change to 96.5 and 98.25 inches, and the lateral limits to -.4 and +.4 inches (see chart on next page).
NOTE: The weight of the float system is not included in the calculation when finding the location of the balance point on the chart.
- C. The horizontal trim fin must have 4 degrees positive pitch (leading edge turned upward) added to the existing setting to compensate for the additional drag on the aircraft.
- D. No sliding of the aircraft on the floats is allowed during take off or landing on any surfaces except water. Damage may occur to the bottom side of the float if sliding occurs.
- E. The complete weight of the float system must be subtracted from the useful load of the aircraft.

Pilot Observations/Precautions:

Any helicopter that is equipped with inflated floats requires a competent pilot with a higher knowledge and skill level. The following observations were noted and should be realized by any pilot prior to flying with an inflated float system.

- A. While hovering the aircraft, most if not all of the ground effect cushion is lost, which results in almost all hover conditions being out of ground effect.
- B. During autorotation, two situations will be different than during normal flight:
 1. The floats attempt to push the aircraft into an inverted position, thus a higher skill of cyclic control is required.
 2. The floats cause the air going through the rotor system to be turbulent, thus the pilot must be more cautious of rotor RPM and flare at the bottom of the autorotation.

WARNING

The construction and operation of "Home-Built Aircraft" of this type is demanding and could inflict serious injury and possible death. No such operation, construction or undertaking should be initiated unless thorough and complete knowledge, preparation and instruction are available and utilized. The seller (and its agents, servants, employees, contractors, successors, and assigns) makes no warranties express or implied regarding the clarity or correctness of the plans, ease of construction or operation, number of building hours required, nor the safety of this aircraft or any part thereof. Furthermore, buyer (and his heirs, administrators and assigns) releases and holds said seller (and its agents, servants, employees, contractors, successors, and assigns) harmless from any and all liability, damages, and causes of action which may be incurred by buyer or any third party as a result of the purchase, use, construction and/or operation of said aircraft (or any part thereof) or plans for same. Buyer assumes all risk and responsibility relative to the construction and/or operation of said aircraft. Seller admits no liability by publication of this warning.

Section 10. HELIPAC Cargo Container

- A. The Helipac unit must be installed according to the directions provided by RotorWay International.
 - B. The container may be slid toward the pilot's side for easier access while loading and unloading. However, it must be in the centered position during flight, and the safety bolt must be installed to prevent the container from moving during flight.
 - C. All cargo must be secured and must not be allowed to shift inside the container during flight, or it will affect the aircraft's center of gravity. The eye bolts at the four inside corners of the container can be used to attach bungee cords, straps, or other anchoring devices. The caution label must be applied to the inside of the container in a place where it is clearly visible.
 - D. The weight of the Helipac unit and any cargo must be subtracted from the useful load of the aircraft.
 - E. Weight and balance with cargo in Helipac:
With cargo in the container, the location and the amount of weight must be considered and added when calculating weight and balance.
 - F. **Fore and aft arm inch**
Empty Helipac Station 88"
- Lateral arm inch**
Empty Helipac Station 0"